



● YOUR
● SMART
● ENERGY

STORION-G2-H50-O

COMMERCIAL &
INDUSTRIAL SERIES

POWER

50 kW Hybrid Inverter

CAPACITY

- 6.9 kWh Battery Module
55.29 / 110.59 kWh
- 8.0 kWh Battery Module
96.76 / 193.52 kWh



KEY FEATURES

- **All in One Design**
The cabinet contains batteries, PCS, DC/DC, STS, HVAC and EMS, but only occupies a small area.
- **Support Multi-Direction Roof**
PV Input: 4*MPPT with 200V ~ 850V MPPT Voltage
- **Multiple System Operation Monitoring**
Local SCADA Monitoring & Remote Commercial and Industrial Cloud
- **Max 5 systems in on-grid parallel, 3 systems in off-grid parallel**
Single system switching time $\leq 20\text{ms}$, parallel system switching time $\leq 100\text{ms}$

STORION-G2-H50-O



System Functions

- Backup
- Max 5 Systems in Parallel
- Peak Shaving and Load Shifting
- Timed Charge and Discharge

System Diagram

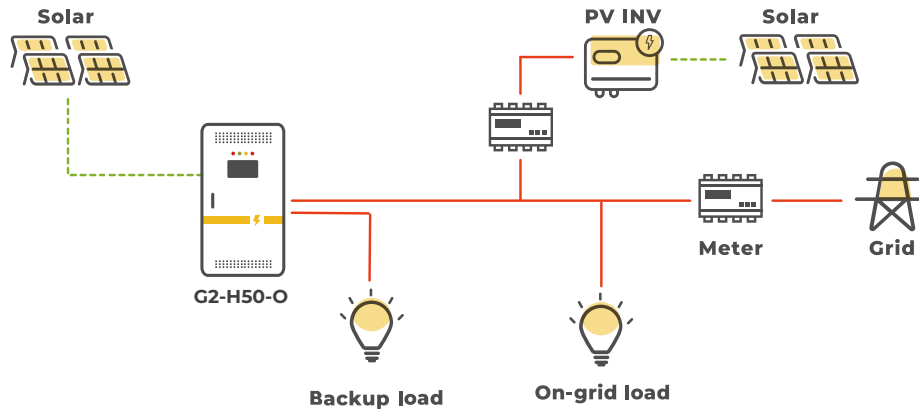

Model	STORION-G2-H50-O
System Technical Specifications	
Battery Chemistry	LiFePO4
Battery Energy Range	55.29 kWh / 96.76 kWh
Depth of Discharge (DoD)	90% (On-Grid), 85% (Off-Grid)
IP Protection	IP55
Standard Battery Cluster	1*
Warranty	5 Years Product Warranty, 10 Years Battery Performance Warranty
PV Side	
Max. input power	75 kW
Start-up voltage	135 V
MPPT Voltage Range	200 ~ 850 V
Number of MPPT	4
Number of Strings for Each MPPT	2
Max. Input Current	30 A / 30 A / 30 A / 30 A
Max. Short-circuit Current	40 A / 40 A / 40A / 40 A
AC Data (Grid)	
Rated Output Power	50 kW
Max. Input Power	60 kW
Rated Grid Voltage	3L / N / PE 220 V / 380 V; 230 V / 400 V
Grid Frequency	50 / 60 Hz
Rated Current	83 A
Output THDi	<3%
AC PF	0.8 leading ... 0.8 lagging
AC Data (Backup)	
Rated Output Power	50 kW
Max Output Apparent Power	55 kVA
Rated Grid Voltage	3L / N / PE 220 V / 380 V; 230 V / 400 V
Grid Frequency	50 / 60 Hz
Max Current	83 A
General Data	
Dimensions (W x D x H)	(1200+300) x 900 x 2160 mm
Weight	1071 kg (with 8*M7790-S) / 1355 kg (with 12*M38210-SC)
Operating Temperature Range	-20 °C ~ 50 °C (PCS > 45°C derating)
Relative Humidity	0~95% (No Condensation)
Max. Working Altitude	3000 m / 9842 ft (>3000 m derating)
Cooling Method	Forced Air-Cooling
Communication Interfaces	RS485, CAN, Modbus TCP, Ethernet
Display	SCADA
Certifications	IEC 62477, IEC 61000, IEC 62109, EN 50549-1, VDE 4105, G99, G100, C10/C11**, TOR Erzeuger**, NC RFG, UNE 217001/2**

* Max support 2 battery clusters, extra battery cabinet is needed.



**The certification process is ongoing.

STORION-G2-H50-O



Model: STORION-G2-H50-O

Battery Cluster System

Item	Data		
Battery Module		M7790-S 1C	M38210-SC 0.5C
Battery Chemistry		LiFePO4	LiFePO4
Pack		3.2 V / 90 Ah@1P24S	3.2 V / 105 Ah@2P12S
Internal Resistance		≤10 mΩ	≤10 mΩ
Nominal Capacity		6.912 kWh	8.064 kWh
Rated Voltage		76.8 V	38.4 V
Operating Voltage		72 V ~ 84.48 V	36 V ~ 43.2 V
Max. Charging/Discharging Current		90 A	105 A
System Cycle Life		6000***	6000***
Operating Temperature Range		-10 °C ~ 50 °C****	-10 °C ~ 50 °C****
IP Protection		IP21	IP21
Communication		CAN	CAN
Dimensions (W x D x H)		326 x 654 x 250 mm	325 x 658 x 232 mm
String Pack QTY		8	12*****
Certifications	IEC 62619, IEC 62477, IEC 61000		

Meter (Optional)



Model	DTSU666
Rated Voltage	230V AC / 400V AC
Accuracy Class	±1%
Communication	RS485, Modbus RTU
Dimensions (W×D×H)	72×80×101 mm
CT Model	AKH-0.66, K-30×20
CT Current Ratio	400 / 5 A
CT Perforation Size	32×22 mm

Expansion Battery Cluster (Optional)



Model	ALPBC-105-O	
Battery	M7790-S	M38210-SC
Cluster Capacity	55.29 kWh	96.76 kWh
Max. Charging/Discharging Current	90 A	105 A
Battery Cluster Voltage Range	576 V ~ 675.8 V	432 V ~ 518.4 V
Battery Rack	2 x 6	
Fire-Fighting System	Aerosol+Smoke/Temperature Detect	
Dimensions (W×D×H)	1200 x 900 x 2160 mm	
Weight	996 kg	1280 kg

***Under specific test conditions.

****Max. charge/discharge current derating may occur with changes in temperature and SoC.

*****When operating with 12 or more 38210-SC batteries, the system is capable of achieving a maximum charging and discharging power of 50 kW.



"BIGGER & STRONGER"

Commercial & Industrial Solution Supports Your Business

AlphaESS is a world-leading energy storage solution and service provider covering the full power range.

 @AlphaEnergyStorageSystem  @AlphaESS  @alpha_ess  @AlphaESS  www.alphaess.com

Alpha ESS Co., Ltd.

Tel: +86 513 8060 6891
Email: info@alpha-ess.com
Website: www.alphaess.com
Add: No. 1086 Bihua Road, Tongzhou District,
Nantong City, Jiangsu Province, China

Alpha ESS International Pte. Ltd.

Tel: +65 6513 1125 / +65 6513 1126
Email: Singapore@alpha-ess.com
Add: 2 Corporation Road #01-06A Corporation
Place 618494 Singapore

Alpha ESS Australia Pty. Ltd.

Tel: +61 02 9000 7676
Email: techsupport@alphaess.au
Website: www.alphaess.au
Add: 8/15-21 Gibbes Street, Chatswood,
NSW 2067 Australia

Alpha ESS Europe GmbH

Tel: +49 6103 4591 601
Email: europa@alpha-ess.de
Website: www.alpha-ess.de
Add: Paul-Ehrlich-Straße 1a, Langen, Hessen D-63225
Germany

Alpha ESS UK Ltd.

Tel: +44 330 043 2610
Email: info@alpha-ess.com
Add: Drake house, Long street, Dursley, gl11 4hh UK

Alpha ESS Italy S.r.l.

Tel: +39 339 462 4288
Email: info@alpha-ess.it
Add: Via Del Molinuzzo 83, 59100 Prato (PO), Italy

Alpha ESS USA, Inc.

Tel: +1 408 368 7828
Email: inquiry@alphaess.us
Add: Unit 5 2180 S Ivanhoe St, Denver, CO 80222 USA

Alpha ESS Korea Co., Ltd.

Email: info@alpha-ess.com
Add: 2F, 19-4, Nohyeong 11-gil, Jeju-si, Jeju-do,
Republic of Korea